

Medos



www.medos.pl

- ✓
 - Szeroka gama kolorów, zgodna z kolorami innych produktów firmy MEDOS
 - Wide range of colors corresponding to the other MEDOS products
 - Vaste gamme de couleurs en conformité avec les couleurs d'autres produits MEDOS
 - Широкая цветовая гамма, сочетающаяся с цветами других изделий фирмы MEDOS
- ✓
 - Estetyczne wykonanie oraz atrakcyjne wzornictwo
 - High quality finish and modern design
 - Aspect esthétique et design attrayant
 - Высокое качество и привлекательный дизайн
- ✓
 - Prosty montaż
 - Easy to assembly by one person
 - Montage facile
 - Быстрый монтаж
- ✓
 - Bezstopniowa regulacja w 3 płaszczyznach bez konieczności podnoszenia i zdejmowania skrzydła
 - Smooth and stepless adjustment in 3 dimensions
 - Réglage en 3 directions avec aisance sans besoin de lever et retirer l'ouvrant
 - Плавная регулировка в 3 плоскостях без необходимости снятия створки с дверной рамы
- ✓
 - Solidna i trwała konstrukcja
 - Solid and durable design
 - Construction solide et durable
 - Надежная и прочная конструкция
- ✓
 - Przebadany na 200.000 cykli
 - Tested for 200.000 opening – closing cycles
 - Paumelles testées pour 200.000 cycles
 - Прошла испытания на 200.000 циклов



Testy ■ Tested ■ Testes ■ Протестирована

- 120 kg/kg - 200,000 cykli/cycles/циклов
- 240 kg/kg - 20 cykli/cycles/циклов
- 360 kg/kg - 5 cykli/cycles/циклов



JOCKER PCV 120KG

4	7	6	0	1	3	1	13

Testy ■ Tested ■ Testes ■ Протестирована

- 80 kg/kg - 200,000 cykli/cycles/циклов
- 160 kg/kg - 20 cykli/cycles/циклов
- 240 kg/kg - 5 cykli/cycles/циклов



JOCKER PCV JUNIOR 80KG

3	7	4	0	1	3	1	11
---	---	---	---	---	---	---	----

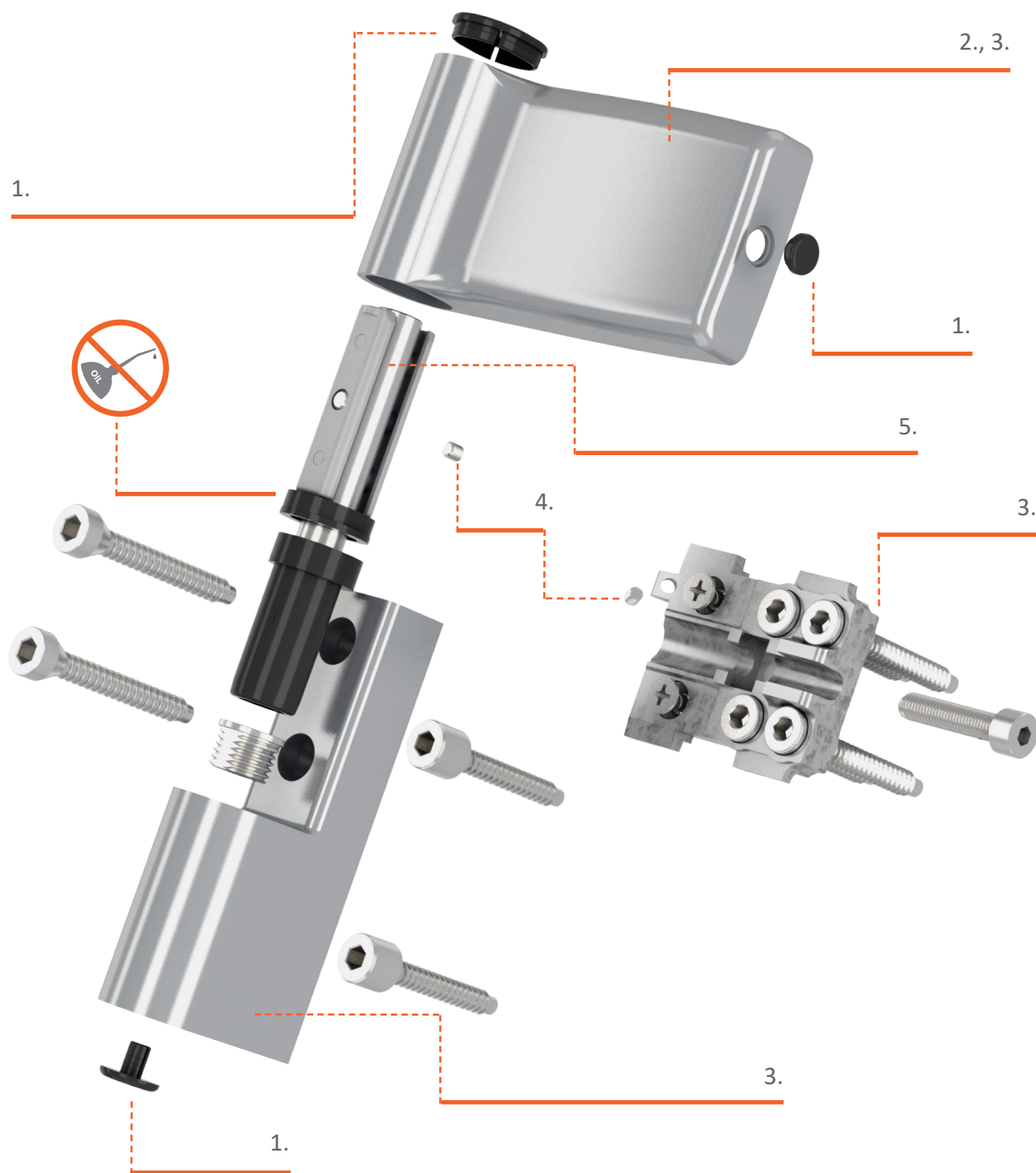

1. Zaślepki wykonane z tworzywa ASA gwarantują utrzymanie intensywności koloru w długim okresie czasu
 - Hinge caps made of ASA plastic keep the colour unchanged for many years
 - Bouchons faits en polymère ASA garantissent le maintien prolongé de l'intensité de la teinte
 - Наружные заглушки петли изготовлены из ASA-пластика и гарантируют цветостойкость в течение долгих лет
2. Monolityczna struktura zawiasu
 - The monolithic structure of the hinge
 - Construction monocoque de la paumelle
 - Целостная форма петли
3. Część ramowa, skrzydłowa oraz wkładka montażowa wykonane z wysokiej jakości stopu ZNAL
 - Frame and sash part made of high quality Znal alloy
 - Lame dormant, lame ouvrant et pièce de fixation faites en zamak de haute qualité
 - Рамная часть, створочная часть и монтажный вкладыш выполнены из сплава ZNAL высокого качества
4. 2 zabezpieczenia antywłamaniowe
 - 2 anti-theft protections
 - 2 protections anti-effraction
 - 2 противовзломных приспособления
5. Teflonowe łożysko ślizgowe
 - Maintenance-free PVC bushings containing teflon
 - Palier sans entretien contenant du téflon
 - Тefлоновая шайба

Zawias drzwiowy Jocker (120 kg) ■ Jocker (120 kg) Hinge for PVC-u doors ■ Paumelle Jocker pour PVC (120 kg) ■ Дверная петля Jocker (120 кг)



-Nº: 901SILV175A

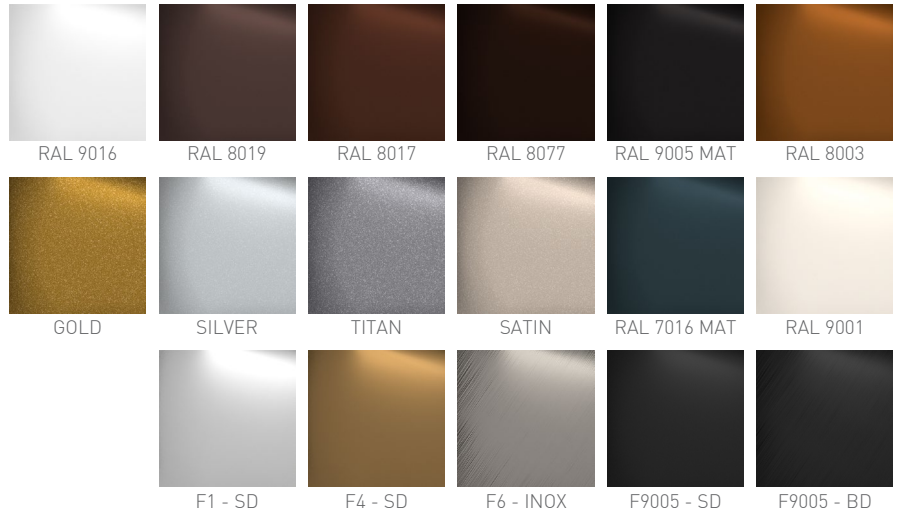

L (mm)	Zakres / Range / La gamme / Диапазон (mm)
15,5	13,2 - 17,8
17,5	15,2 - 19,8
20,5	18,2 - 22,8
24,5	22,2 - 26,8

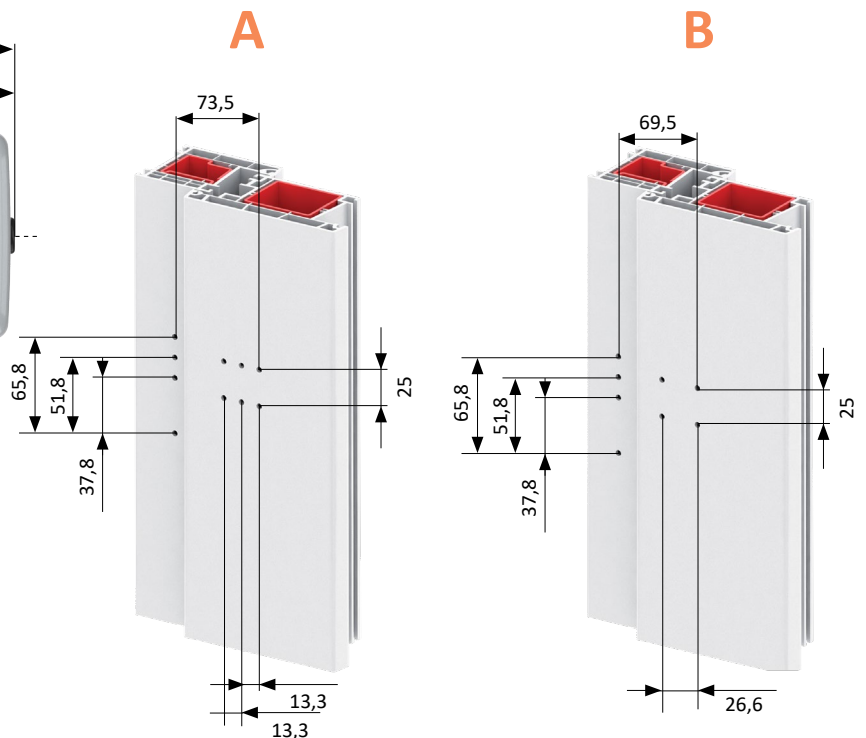
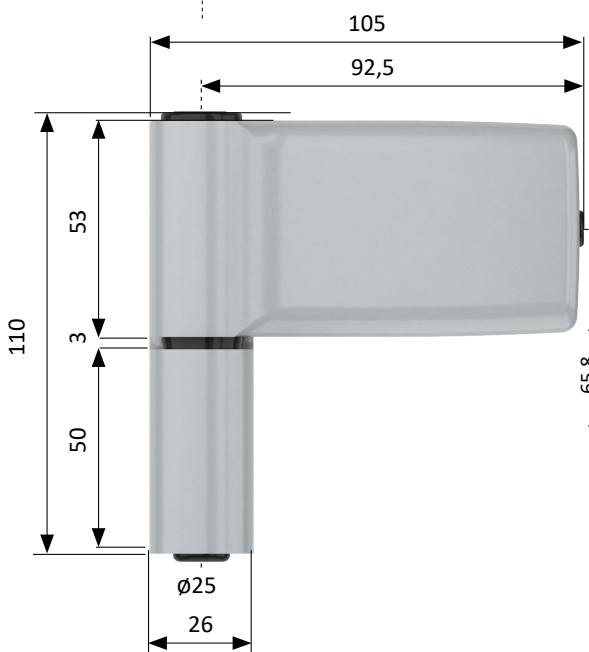
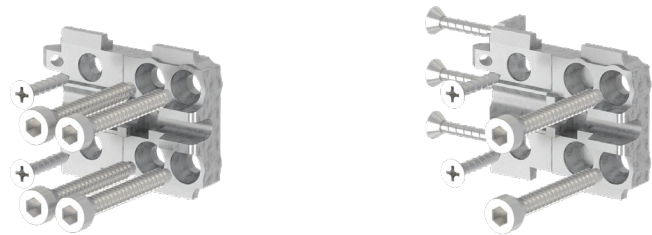
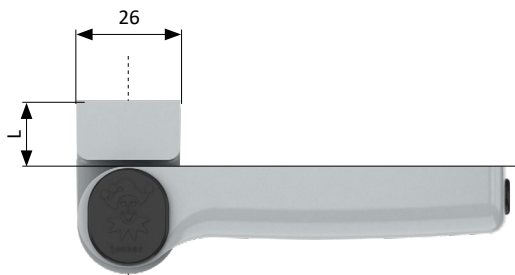

Орcja A ■ Option A ■ Variante A ■ Тип А

Орcja B ■ Option B ■ Variante B ■ Тип Б

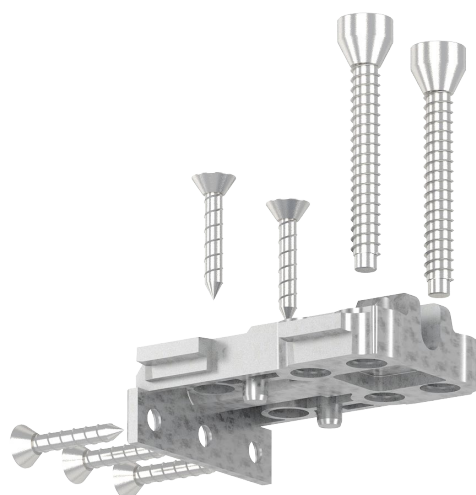
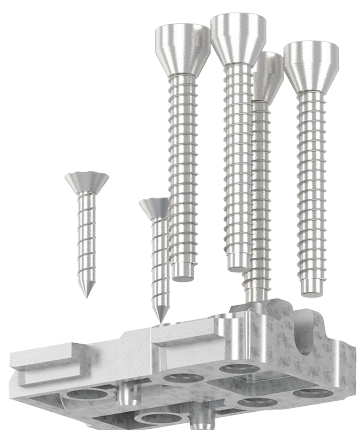
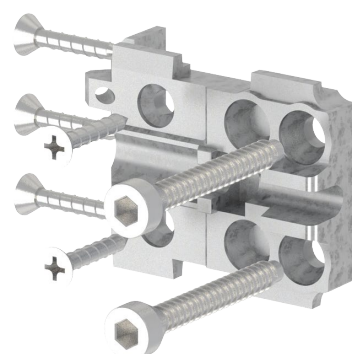
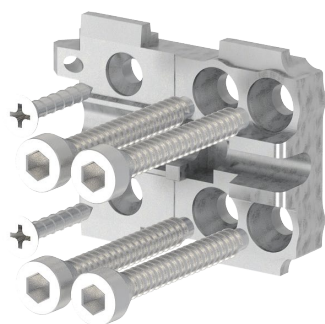
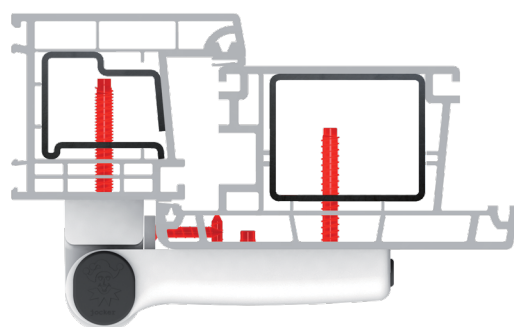
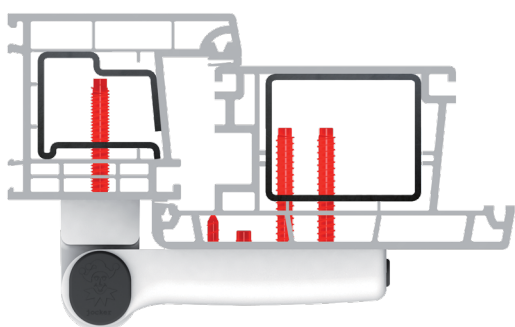

Zawias drzewiowy Jocker Junior (80 kg) ■ Jocker Junior (80 kg) Hinge for PVC-u doors Paumelle ■ Jocker Junior pour PVC (80 kg) ■ Дверная петля Jocker Junior (80 кг)

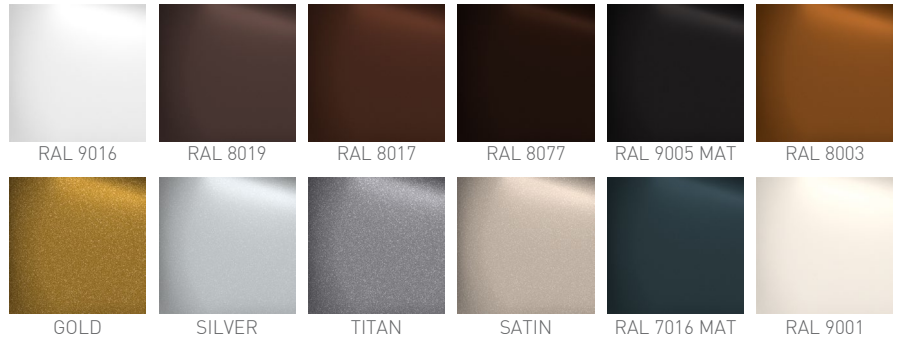

-№: 904SILV175A

L (mm)	Zakres / Range / La gamme / Диапазон (mm)
15,5	13,75 - 17,25
17,5	15,75 - 19,25
20,5	18,75 - 22,25
24,5	22,75 - 26,25

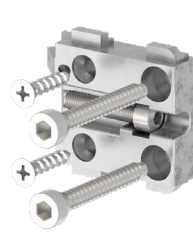
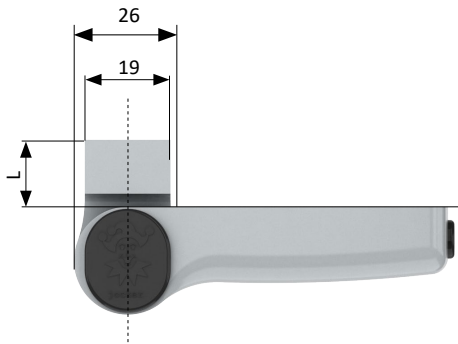

A



B

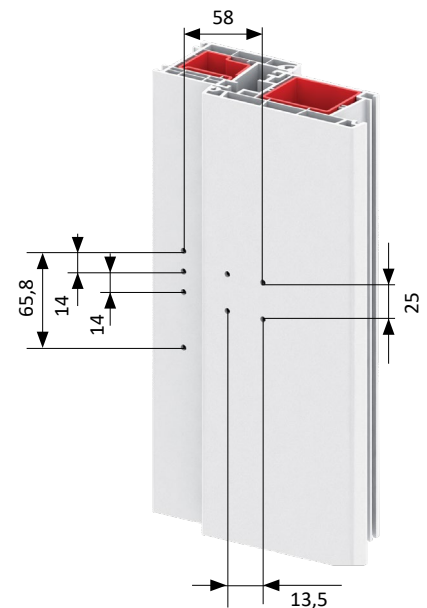
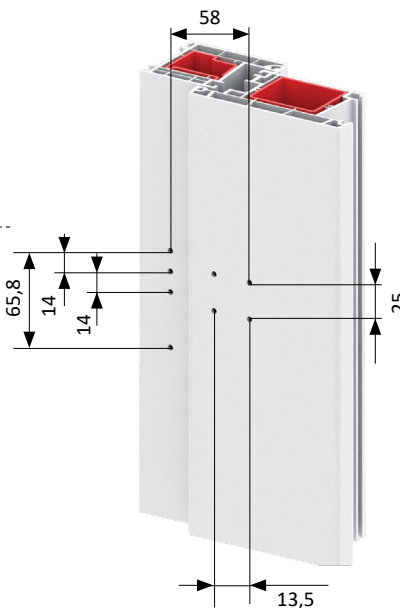
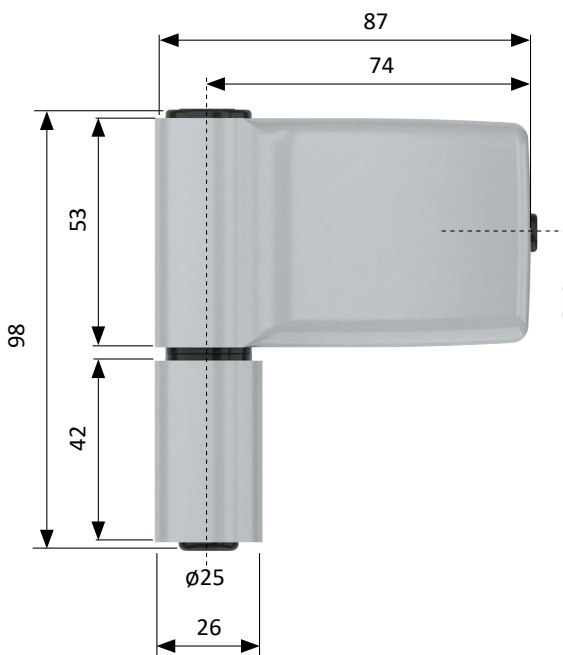

Wersje montażowe Jocker Junior (80 kg) ■ Mounting versions Jocker Junior (80 kg)
■ Variantes de montage de la paumelle Jocker Junior pour PVC (80 kg) ■ Варианты петли Jocker Junior (80 кг)

Орcja A ■ Option A ■ Variante A ■ Тип А

Орcja B ■ Option B ■ Variante B ■ Тип Б

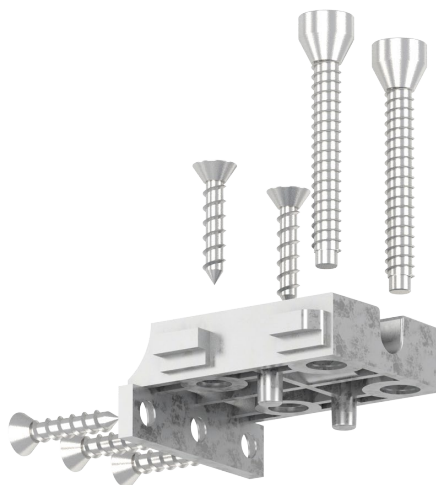
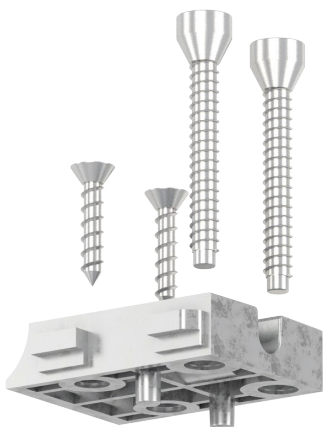
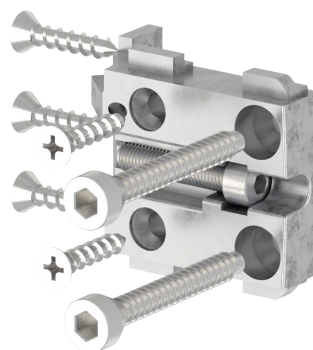
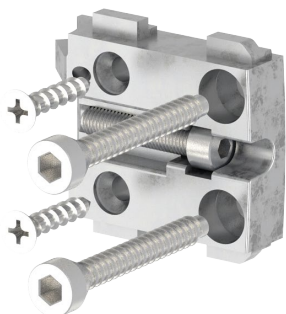
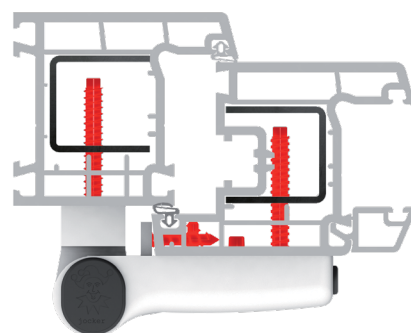
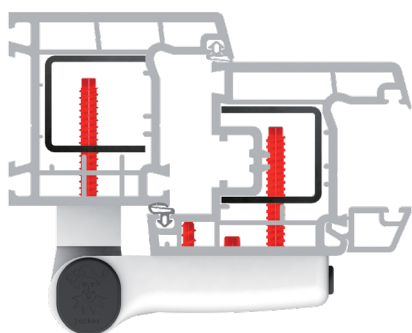

MONTAŻ (120 kg) ■ ASSEMBLY (120 kg) ■ MONTAGE (120 kg) ■ УСТАНОВКА (120 кг)

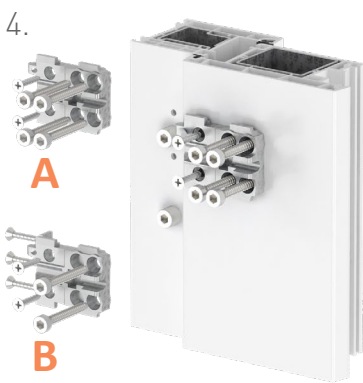
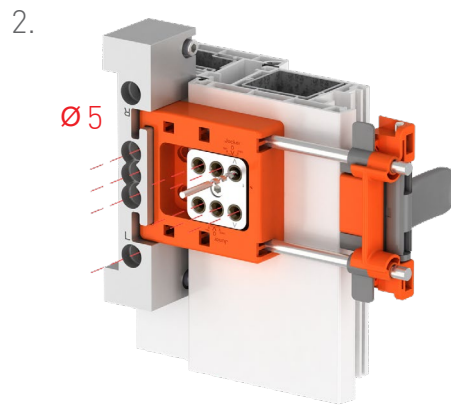
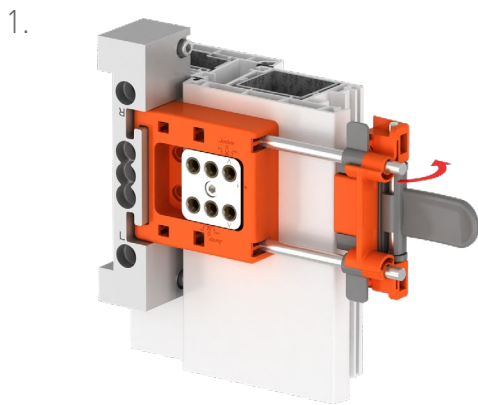



Płynna regulacja zawiasów JOCKER w 6-ciu kierunkach, bez konieczności podnoszenia i zdejmowania skrzydła drzwiowego. Do regulacji zawiasów wystarczy tylko 1 osoba.

PVC door hinges JOCKER are steplessly adjustable in 3 dimensions. Assembly and adjustment on the installed door can be carried out by one person.

Réglage continu des paumelles Jocker dans 6 directions sans besoin de soulever et dégondrer la porte. Le réglage peut être fait par une personne.

Плавная регулировка петель JOCKER в 6-ти направлениях выполняется всего 1 человеком без необходимости снятия дверной створки.

Regulacja w pionie ■ Vertical adjustment ■ Réglage vertical ■ Вертикальная регулировка

Jocker PCV (120 kg/кг)

↑ +4,0
↓ -1,5



Jocker Junior PCV (80 kg/кг)

↑ +4,0
↓ -1,0

Regulacja w poziomie ■ Horizontal adjustment ■ Réglage horizontal ■ Горизонтальная регулировка

Jocker PCV (120 kg/кг)

↔ +4,0
↔ -4,0



Jocker Junior PCV (80 kg/кг)

↔ +4,0
↔ -4,0

Regulacja docisku uszczelki ■ Sealing pressure adjustment ■ Réglage de la compression ■ Регулировка прижима уплотнителя

Jocker PCV
(120 kg/кг)

↖ +2,3
↘ -2,3



Jocker Junior PCV
(80 kg/кг)

↖ +1,75
↘ -1,75

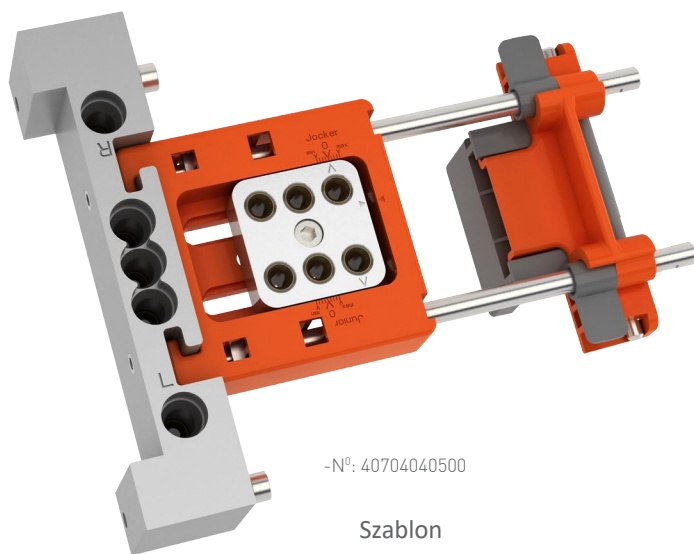

-N^o: 40704040500

Szablon
Template
Gabarit
Шаблон



Maksymalna wysokość skrzydła: 2650mm

Maximum sash height: 2650mm

Hauteur maximale de l'ouvrant: 2650mm

Максимальная высота створки: 2650mm

-N^o: 40704040200

Szablon teleskopowy
Telescopic Template
Gabarit télescopique
Телескопический шаблон



-N^o: 40704040100

Pilot do Jockera PCV
Adjustment tool
Outil de réglage
Установочный шестигранник



DZIAŁ SPRZEDAŻY KRAJOWEJ

Tomasz Poniatowski

Kierownik Działu Handlowego - Polska
Tel. +48 56 691 20 64
Kom. +48 508 186 242
tomek@medos.pl

Zbigniew Myszka

Specjalista ds. Marketingu i Handlu
Tel. +48 56 691 20 75
Kom. +48 609 023 372
zbyszek@medos.pl

Przemysław Lasowski

Specjalista ds. Marketingu i Handlu
Tel. +48 56 691 20 75
Kom. +48 601 277 142
przemek@medos.pl

Marcin Mątewski

Specjalista ds. Marketingu i Handlu
Tel. +48 56 691 20 58
Kom. +48 607 236 009
marcin.m@medos.pl

Karol Przybylski

Specjalista ds. Marketingu i Handlu
Tel. +48 56 691 20 59
Kom. +48 505 079 162
karol.p@medos.pl

Krzysztof Konopacki

Specjalista ds. Marketingu i Handlu
Tel. +48 56 662 74 28
Kom. +48 693 013 401
krzysztof.k@medos.pl

Błażej Gawroński

Specjalista ds. Marketingu i Handlu
Tel. +48 56 662 74 29
Kom. +48 603 030 742
blazej.g@medos.pl

Waldemar Rosiński

Specjalista ds. Marketingu i Handlu
Tel. +48 56 662 74 03
Kom. +48 601 833 175
waldemar.r@medos.pl



INTERNATIONAL SALES

Łukasz Napieralski

International Sales Director
Tel. +48 56 691 20 56
Mob. +48 515 248 576
Fax +48 56 691 20 50
lukasz@medos.pl



EN



ES



RU

Adam Szulc

Export Manager
Tel. +48 56 691 30 97
Mob. +48 609 318 148
Fax +48 56 691 20 50
as@medos.pl



EN

Bartosz Stawicki

Export Manager
Tel. +48 56 69 120 63
Mob. +48 607 173 656
Fax +48 56 691 20 50
bs@medos.pl



EN

Andrzej Mojsiewicz

Export Manager
Tel. +48 56 691 20 70
Mob. +48 502 718 288
andrzej.m@medos.pl



RU



LT

Łukasz Ferenc

Export Manager
Tel. +48 56 691 20 70
Mob. +48 601 945 737
lukasz.f@medos.pl



RU

Grażyna Kierska

Export Manager
Tel. +48 56 662 74 14
Mob. +48 607 856 654
gk@medos.pl



FR



IT



EN



ES

Maciej Zdunowski

Export Manager
Mob. +48 603 702 952
mz@medos.pl



EN



ES



Medos

MEDOS
ul. Magazynowa 3
86-200 Chełmno / Polska

NIP: 875-10-02-162
REGON: 870568014

www.medos.pl

tel.: +48 (56) 56 691 20 79
fax: +48 (56) 691 20 50

